

Socket X1600 5G Deployment Guide

version 1.0
January 2026



Table of Contents

Welcome to Your New Cato Socket	3
Typical Site Topology	3
Prerequisites	3
Administrator Account Onboarding	4
Deploying the X1600 Socket	5
X1600 Socket Known Limitation	5
Connecting the X1600 5G Socket to the Cato Cloud	5
Configuring the 5G Authentication Method	5
Creating an X1600 5G Site in the Cato Management Application	6
Assigning the Socket to a Site	8
Configuring the LAN	8
Working with the X1600 5G Socket	10
Overview of the X1600 5G Socket	10
Front Panel Components	10
Rear Panel Components	11
Right Side Panel Components	12
Left Side Panel Components	13
Mounting the X1600 Sockets - Rackmount	14
Mounting the X1600 Sockets - Wallmount	23
X1600 Wallmount Reference Diagrams	29
Outboard Position	29
Inboard Position	30
Additional Resources	31

Welcome to Your New Cato Socket

This guide explains how to deploy the Socket to a site and connect the site to the Cato Cloud.

You can also watch the following video tutorial on the Cato Academy: [Cato Socket Setup: Unboxing to Rack Ready](#)

Typical Site Topology

A typical deployment scenario is where the Cato Socket replaces the site's existing firewall. There are many other topologies and scenarios that are also supported.

The following diagram shows a typical topology for a site with two Sockets in a high availability (HA) configuration connected to two different ISPs, with 5G configured as a Last Resort link.

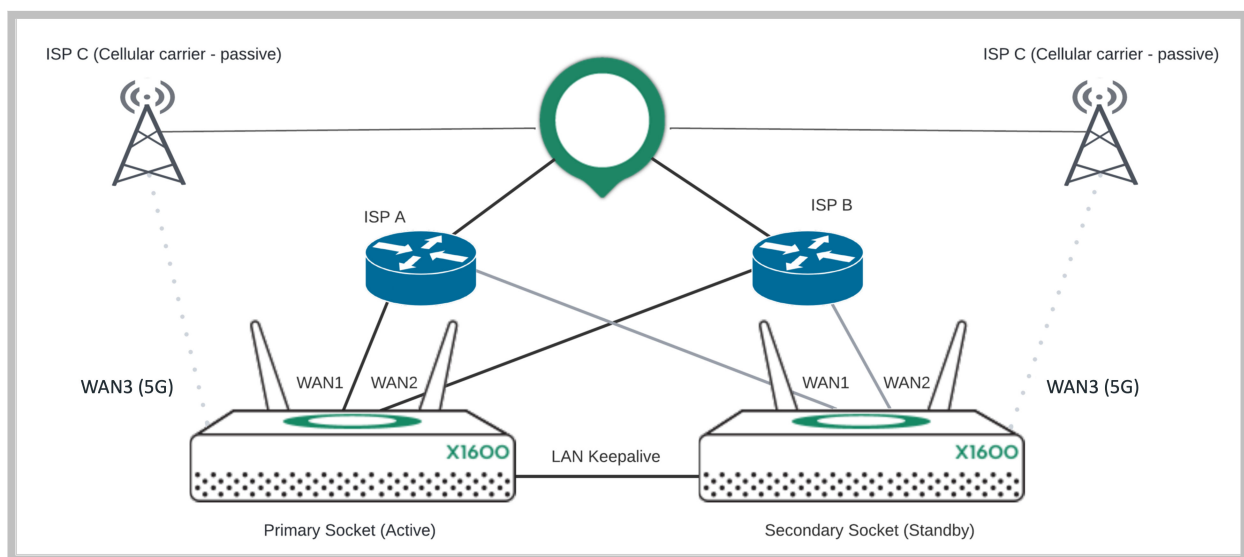

Prerequisites

The following items are required before you start deploying the Socket:

- Cato Socket - The Socket model that was shipped to you
- ISP connection - the Internet connection through which the Socket connects to the Cato Cloud
- WAN IP - a DHCP or statically-assigned IP address
- Native Range - the LAN range that is directed towards the Socket
- DHCP Range - The DHCP assigned range(s) that the Socket supports (optional)
- Gateway IP - The network's gateway's IP address
- Make sure that your networking devices and firewalls meet the requirements listed in [Cato Socket Connection Prerequisites and Known Limitations](#).
- Activated SIM card/s (Micro SIM)
 - PH000 screwdriver to open the SIM drawer
 - (Optional) Nano to Micro SIM adapter. Required if your SIM cards are nano SIM.

Administrator Account Onboarding

- If you already have a Cato Networks account, skip to [Creating an X1600 5G Site in the Cato Management Application \[6\]](#)
- If you already have a Cato Networks account and you have created a site, skip to [Working with the X1600 5G Socket \[10\]](#)

After Cato opens an account for your organization, your account administrator must onboard to the Cato Management Application. This administrative access is required to create, configure, and assign the Socket with the appropriate site.

The onboarding procedure starts when your account's administrator receives an invitation email from Cato Networks.

To set your account password:

1. Click the activation link to redirect to the password configuration window in your browser.
2. Set your password.
3. You will receive a second email and a link to the CMA.

Deploying the X1600 Socket

This is a high-level overview of the process to deploy an X1600 Socket at the physical location of the site:

1. Power on the Socket and connect the WAN links to the Internet ([Connecting the X1600 Socket to the Cato Cloud](#)).
2. Create the site in the Cato Management Application ([Connecting the X1600 Socket to the Cato Cloud](#)).
3. In the Cato Management Application, assign the X1600 Socket to the relevant site ([Assigning the Socket to a Site \[8\]](#)).
4. Edit the site and define the LAN segments ([Configuring the LAN \[8\]](#)).

X1600 Socket Known Limitation

USB2LAN Adapter Compatibility – To connect an ethernet adapter via the USB port, you only connect it after the Socket is registered to your Cato account and fully upgraded to latest Socket version. Otherwise, connecting the ethernet adapter too early can cause interoperability issues.

For more information about supported add-ons, see [Supported Socket Transceivers and USB Ethernet Adapters](#).

Connecting the X1600 5G Socket to the Cato Cloud

Connect the LAN and WAN ports on the X1600 front panel to the internal network and to the ISP.

1. Unbox the Socket.
2. Connect the LAN cables:
 - If the Socket is replacing a firewall, disconnect the Ethernet cable from the firewall and connect the cable to the Socket's LAN port.
 - If the LAN is routed from a network device or existing firewall that is not being replaced, connect the Ethernet cable from the relevant port on that device to the Socket's LAN port.
3. Connect the WAN cables:
 - If the Socket is connected directly to the ISP router, connect the Ethernet cable from the ISP device to the Socket's port 1 (or port 1 and port 2 if you have multiple ISP connections).
4. Connect the antennas to their respective ports.
5. Insert the SIM card(s). If you only have 1 SIM card, make sure to insert it into slot 1.
6. After the LAN and WAN networks are connected, connect the power cable to the power supply input in the rear panel.

Configuring the 5G Authentication Method

If your cellular provider requires specific authentication, either PAP or CHAP, you must configure the settings in the Socket management, using the Socket Web UI.

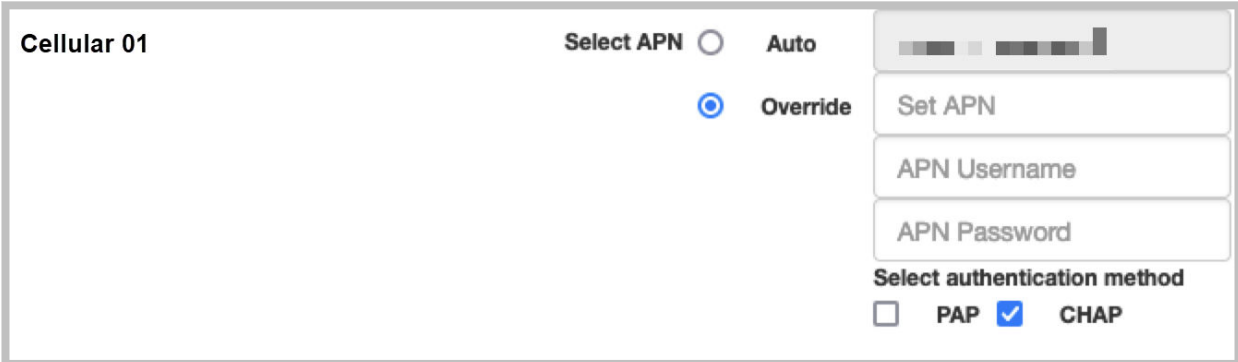

Cellular 01

Select APN Auto Override

Set APN

APN Username

APN Password

Select authentication method

PAP CHAP

To configure the authentication method:

1. From the navigation menu, click **Network > Sites** and select the site.
2. From the navigation menu, click **Site Configuration > Socket**.
3. From the **Actions** menu of the socket, select **Socket WebUI**.
4. In the Socket WebUI, navigate to the Network Settings page, and under the APN settings, click **Override**.
5. Enter the APN settings and select the **PAP** or **CHAP** checkboxes.
6. Click **Update**.



Note: If you need to reset the SIM registration, update the authentication method and only then navigate to the Administration page to set the **Initial EPS bearer settings for 5G Modem**.

Creating an X1600 5G Site in the Cato Management Application

Create a site in the Cato Management Application (CMA) for the site where you are deploying your new Socket.

To create a new X1600 Socket site:

1. Log in to the CMA.
2. From the navigation menu, click **Network > Sites**.
3. Click **New**. The **Add Site** panel opens.

✕ Add Site

General

Site Name *
Sample X1600 Cellular Site

Site Type
Branch

Connection Type *
Socket X1600 Cellular

Country *
Search or select Country

State
Search or select State

Timezone *
London (Europe)

City *
Search or select City

WAN Interface Settings

Enable WAN2

WAN1 Last-mile Bandwidth:	?	Downstream (Mbps) * 100	?	Upstream (Mbps) * 100
WAN2 Last-mile Bandwidth:	?	Downstream (Mbps) * 100	?	Upstream (Mbps) * 100
Cellular (Last Resort) Bandwidth:	?	Downstream (Mbps) * 50	?	Upstream (Mbps) * 50

LAN Interface Settings

Native Range e.g. 192.0.2.0/24	VLAN
VLAN ID should be empty or set to 1-4094	

Apply
Cancel

4. Configure the **General** settings for the site:
 - a. Enter the **Site Name**.
 - b. Select the **Site Type**. This option determines which icon is used for the site in the **Topology** window.
 - c. In **Connection Type**, select **Socket X1600 Cellular**.
 - d. Configure the **Country**, and **State**, for the physical location of the site.

- e. **(Optional)** Customize the **Time Zone**. This setting is used to set the time frame for the Socket update Maintenance Window.
- 5. In the **WAN Interface Settings** section, configure the settings for the Sockets:
 - a. If the site uses a link for the secondary ISP connection, select **Enable WAN2**.
IMPORTANT: If you are connecting a single ISP to WAN2, select this option to prevent connectivity loss when first connecting to Cato Cloud.
 - b. Enter the values (in Mbps) for the **WAN1 Bandwidth** and **WAN2 Bandwidth** for **Downstream** and **Upstream**.
Note: Your upstream and downstream bandwidth for the WAN1 and WAN2 links are set according to the ISP bandwidth and the license that was purchased from Cato.
 - c. If necessary, repeat the previous step for the **WAN2 Bandwidth**.
 - d. If you are implementing 5%, enter the values (in Mbps) for **5G Bandwidth** for **Downstream** and **Upstream**.
5G should only be configured as a [Last Resort](#).
- 6. In the **LAN Interface Settings** section, configure the **LAN Native Range** for the site.
You can't use /31 or /32 CIDR blocks.

Assigning the Socket to a Site

Once a Socket is up and running, it automatically connects to an optimal PoP in the Cato Cloud and checks if a new version of the Socket firmware is available.



If the Socket detects that a new version of the firmware is available, it automatically performs an upgrade, and the CMA shows the **New Socket Detected** notification.

When the Socket has the latest firmware, the CMA displays the **Activate New Socket** notification and sends an email to the Activate New Socket mailing list. You can then activate and assign the Socket to the relevant site.

To activate the Socket and assign it to a site:

1. Click the notification icon .
2. In the list, locate the **Activate New Socket** notification and click **ACCEPT**.
3. In the **Assign Cato Socket to Site** window, in **Choose Site to assign Socket**, select the site for the new Socket and click **OK**.
4. The site is shown as connected in the **Monitoring > Topology** screen.

Configuring the LAN

After you create the site, configure the network settings for the LAN.

LAN 01							New
Type	IP Ranges		Characteristics		VLAN	Name	DHCP Settings
Native	Subnet:	10.0.0.0/24	Local IP:	10.0.0.1			Account Default
Direct	Subnet:	10.0.0.0/27	Local IP:	10.0.0.1		Secure segment	Disabled

To configure the LAN settings for the site:

1. From the navigation menu, click **Network > Sites** and select the new Socket site.
2. From the navigation menu, click **Site Configuration > Networks**.
3. Expand the LAN interface.
4. Review the **Local IP** and **DCHP Settings** for the site.
For more about configuring the settings for a site, see the [network range articles](#) in the Cato Networks Knowledge Base.

Working with the X1600 5G Socket



Overview of the X1600 5G Socket

This section describes the components on the X1600 Socket panels.

Front Panel Components

These are the LED indicators on the front panel of the X1600 5G Socket:



Icon	Description
	<p>Socket LED</p> <ul style="list-style-type: none"> • off - Socket is powered off and disconnected from the power supply • green - Socket is powered and ready • blue - Socket OS firmware is installed • amber - Socket is powered off and connected to the power supply
	<p>Network Connectivity LED</p> <ul style="list-style-type: none"> • green - Full connectivity to Internet and the Cato Cloud • blue - Full connectivity to Internet, no connectivity to the Cato Cloud • red - No network connectivity
	<p>Cellular Connectivity LED</p> <ul style="list-style-type: none"> • green - Full connectivity to the Internet • blue - Poor connectivity to the Internet • red - No network connectivity

Rear Panel Components

These are the rear panel components of the X1600 5G Socket:

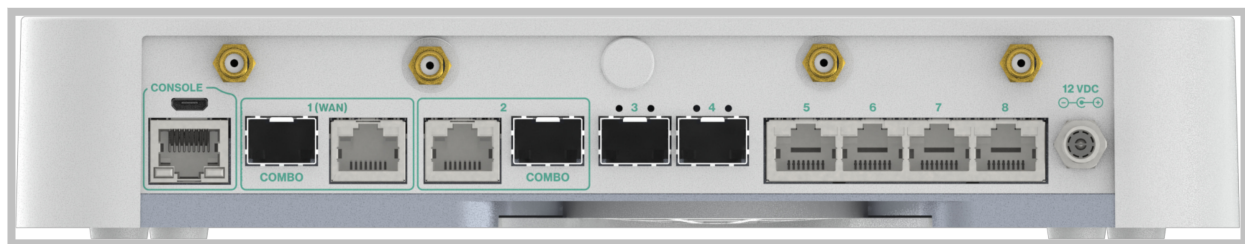

Name	Description	LED Description
Connectors (antenna)	<p>Antenna connectors</p> <p>When setting up the antennas, we recommend that you position them the same way for best reception.</p>	N/A
Console	Used by Support to troubleshoot the Socket. Supports an RS-232 cable, or any micro USB cable.	<ul style="list-style-type: none"> • RS-232 Cable connected <ul style="list-style-type: none"> ◦ Left LED - N/A ◦ Right - Green
1	<p>1 Gbps copper or 1 Gbps fiber for WAN traffic</p> <ul style="list-style-type: none"> • You can only connect one cable • Supports auto-negotiation and full-duplex up to 1 Gbps 	<ul style="list-style-type: none"> • Link has connectivity <ul style="list-style-type: none"> ◦ Right LED - Green • Link is active <ul style="list-style-type: none"> ◦ Right LED - Blinking green • 1 Gbps speed <ul style="list-style-type: none"> ◦ Left LED - Orange
2	<p>1 Gbps copper or 1 Gbps fiber</p> <ul style="list-style-type: none"> • You can only connect one cable • Supports auto-negotiation and full-duplex up to 1 Gbps 	<ul style="list-style-type: none"> • Link has connectivity <ul style="list-style-type: none"> ◦ Right LED - Green • Link is active <ul style="list-style-type: none"> ◦ Right LED - Blinking green • 1 Gbps speed <ul style="list-style-type: none"> ◦ Left LED - Orange
3 & 4	<p>10 Gbps fiber</p> <ul style="list-style-type: none"> • 1 Gbps transceivers are not supported • Auto-negotiate is not supported 	<ul style="list-style-type: none"> • Link has connectivity <ul style="list-style-type: none"> ◦ Right LED - Green ◦ Left LED - Green • Link is active <ul style="list-style-type: none"> ◦ Right LED - Blinking green ◦ Left LED - Green

Name	Description	LED Description
5 - 8	2.5 Gpbs copper ports By default, port 8 is the MGMT port Auto-negotiate is supported	<ul style="list-style-type: none"> Link has connectivity <ul style="list-style-type: none"> Right LED - Green Link is active <ul style="list-style-type: none"> Right LED - Blinking green 1 Gbps speed <ul style="list-style-type: none"> Left LED - Orange 2.5 Gbps speed <ul style="list-style-type: none"> Left LED - Green
12 VDC	Power supply input	N/A

Right Side Panel Components

These are the right side panel components of the X1600 5G Socket:



Name	Description
SIM 2	<p>SIM slot 2</p> <p>When inserting the SIM card into slot 2, make sure that the circuits are face DOWN.</p>

Name	Description
SIM 1	<p>SIM slot 1</p> <p>When inserting the SIM card into slot 1, make sure that circuits are face UP.</p> 
Additional SIM slots	<p>The additional SIM slots are currently not operational and are reserved for future use.</p>

Left Side Panel Components

These are the left side panel components of the X1600 5G Socket:

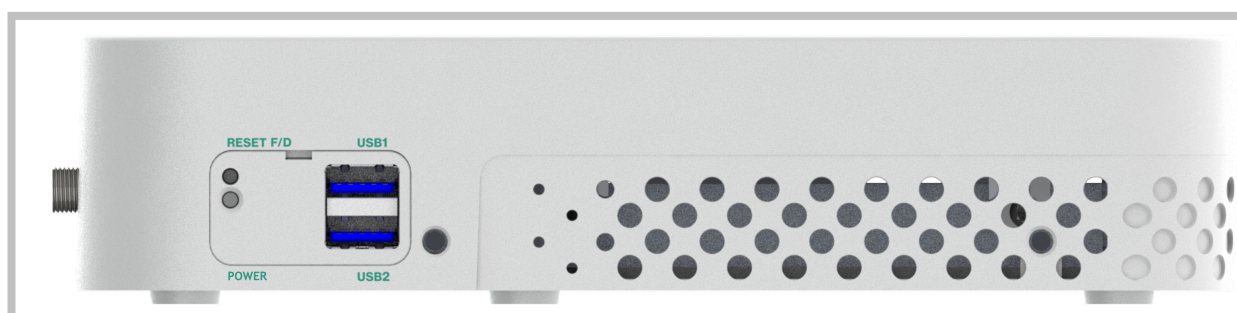

Name	Description
USB1	USB 3.0 port
USB2	USB 3.0 port
RESET F/D	<p>Reset button - resets the Socket</p> <ul style="list-style-type: none"> Reset Socket WebUI password to admin - press for 5 - 15 seconds Reset Socket, delete all configuration files, and unassign from the site - press for 25 - 35 seconds
Power	<p>Power button - Powers the Socket on and off</p> <ul style="list-style-type: none"> Power off Socket - press for 10 seconds Power on Socket - press for 3 seconds <p>(Additional features will be added in the future)</p>

Mounting the X1600 Sockets - Rackmount

To mount the X1600 Socket in a server rack:

1. Insert the X1600 Socket into the rackmount bracket, oriented as shown.

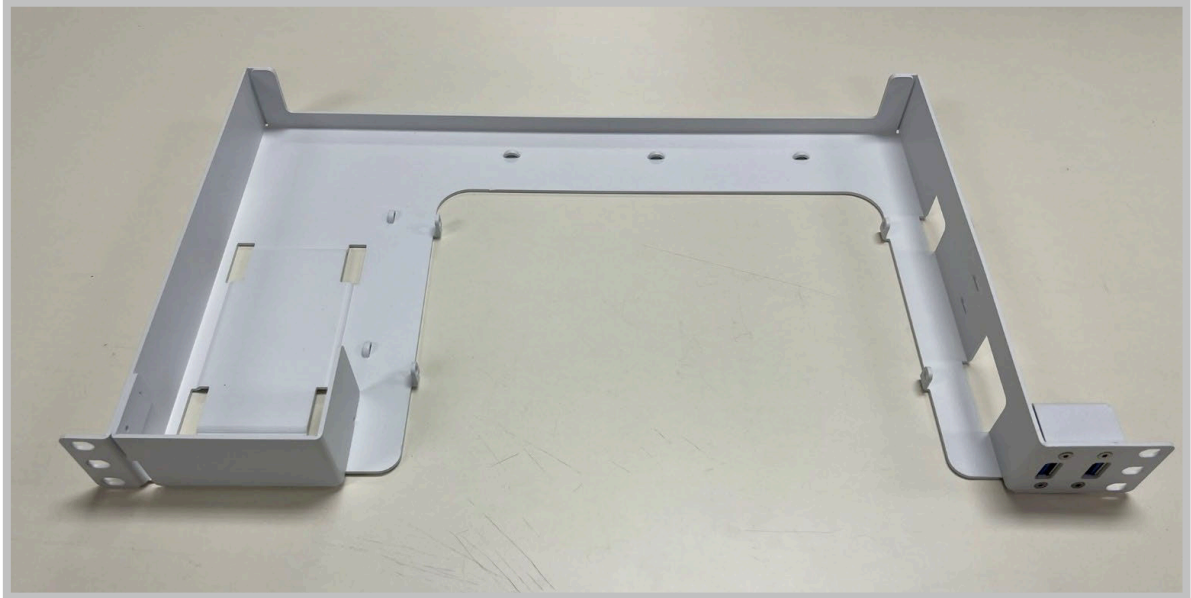

2. Align the mounting holes in the X1600 Socket with the holes located in the tabs on the rackmount bracket.



3. Insert a screw into one of the mounting holes and snug. Do not overtighten.



4. Insert the remaining screws into the mounting holes and snug. Do not overtighten.
 - Right-side view



- Left-side view



5. Install USB cables between the USB 3.0 Micro B connections on the rackmount bracket and the USB 3.0 Type A connections on the X1600 Socket.



6. Secure the cables in place with a 300mm cable tie passed through the cable tie mounts on the rackmount bracket and snip off the excess.

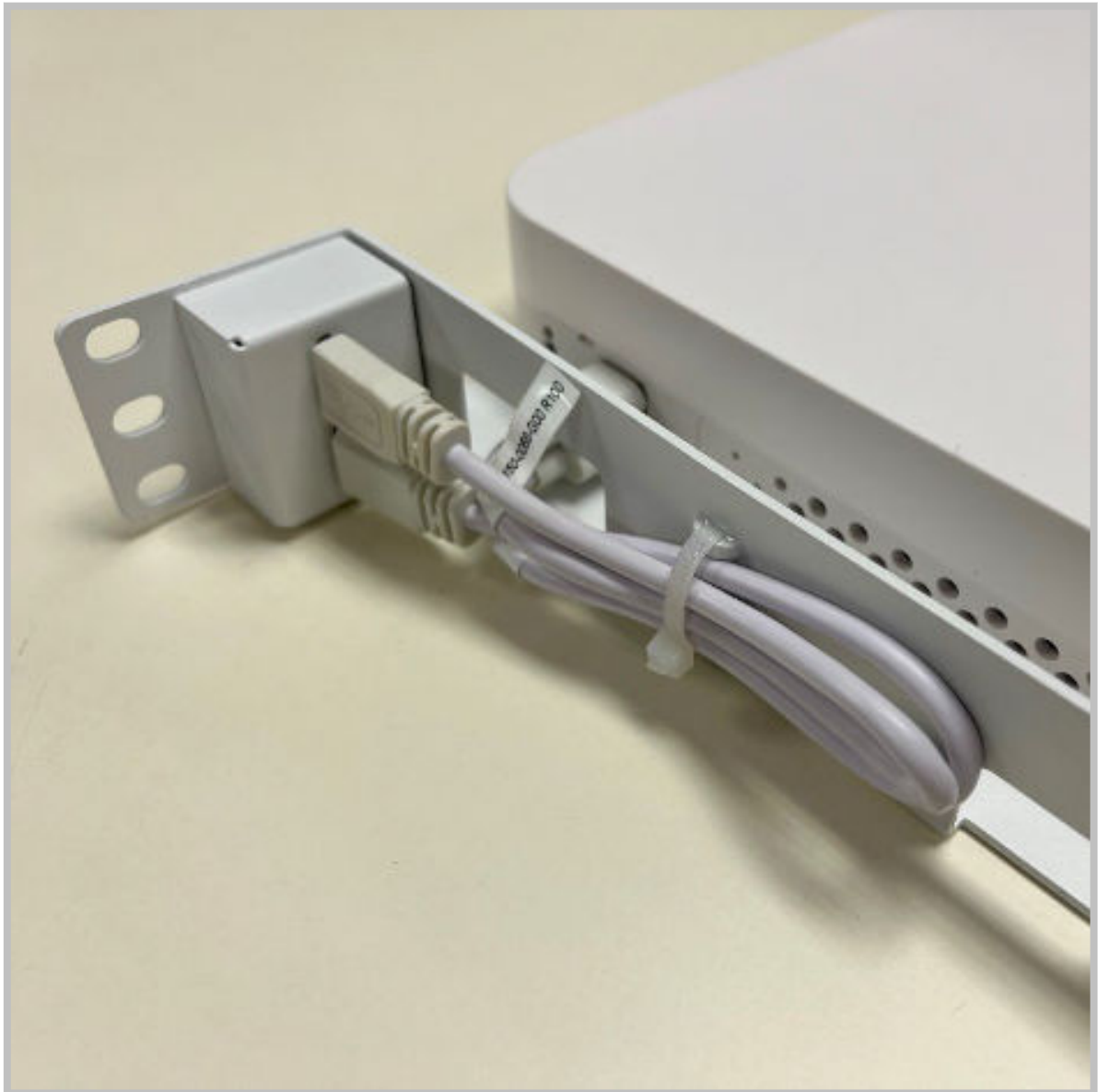

7. Route two 300mm cable ties underneath the PSU standoff on the rackmount bracket. Place the PSU on the standoff with the cables oriented as shown.

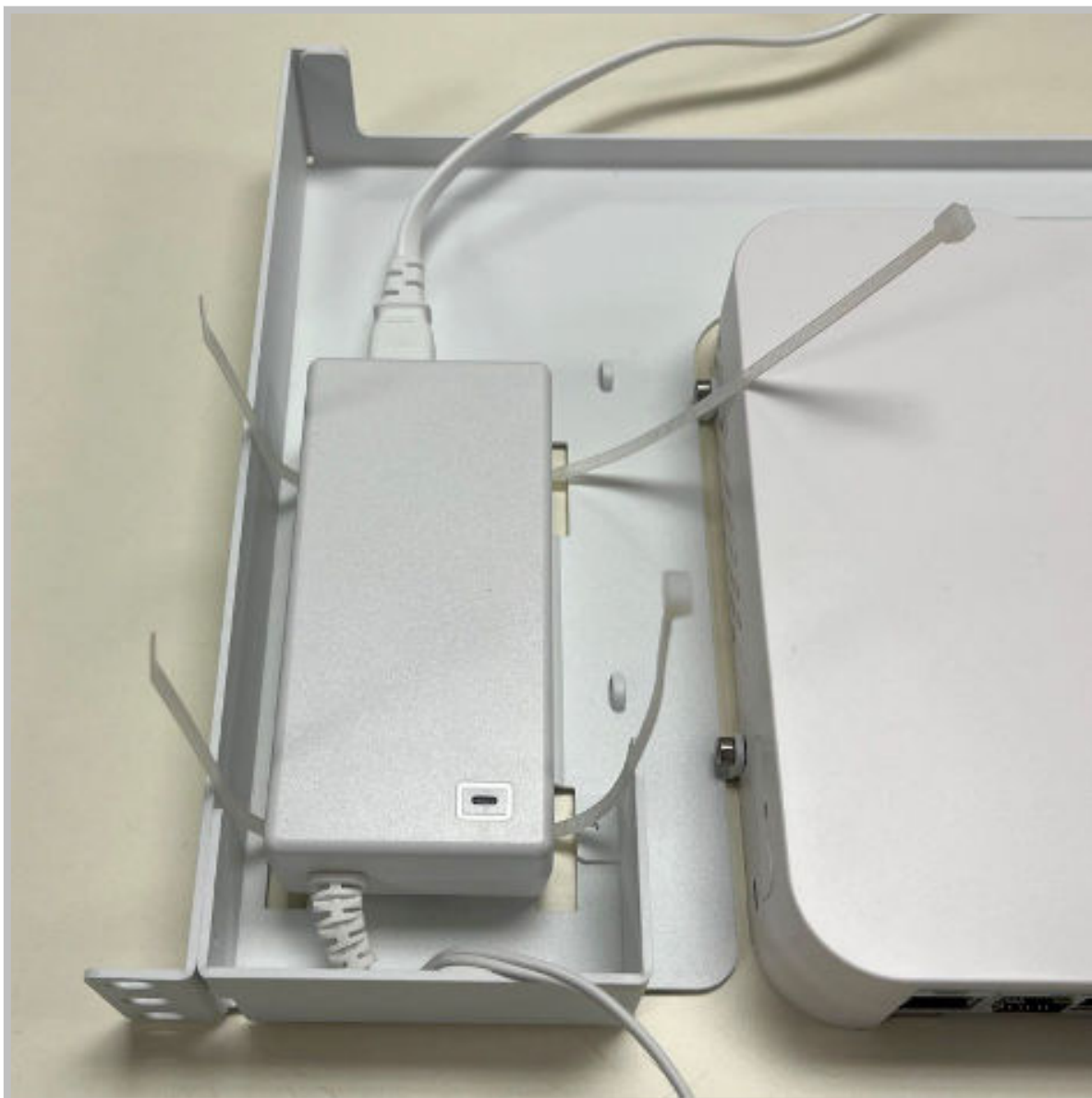

8. Secure the PSU to the rackmount bracket with the cable ties and snip of the excess. Screw the power cable into the X1600 Socket.



9. Route five 99mm cable ties through the cable tie mounts on the rackmount bracket where shown.

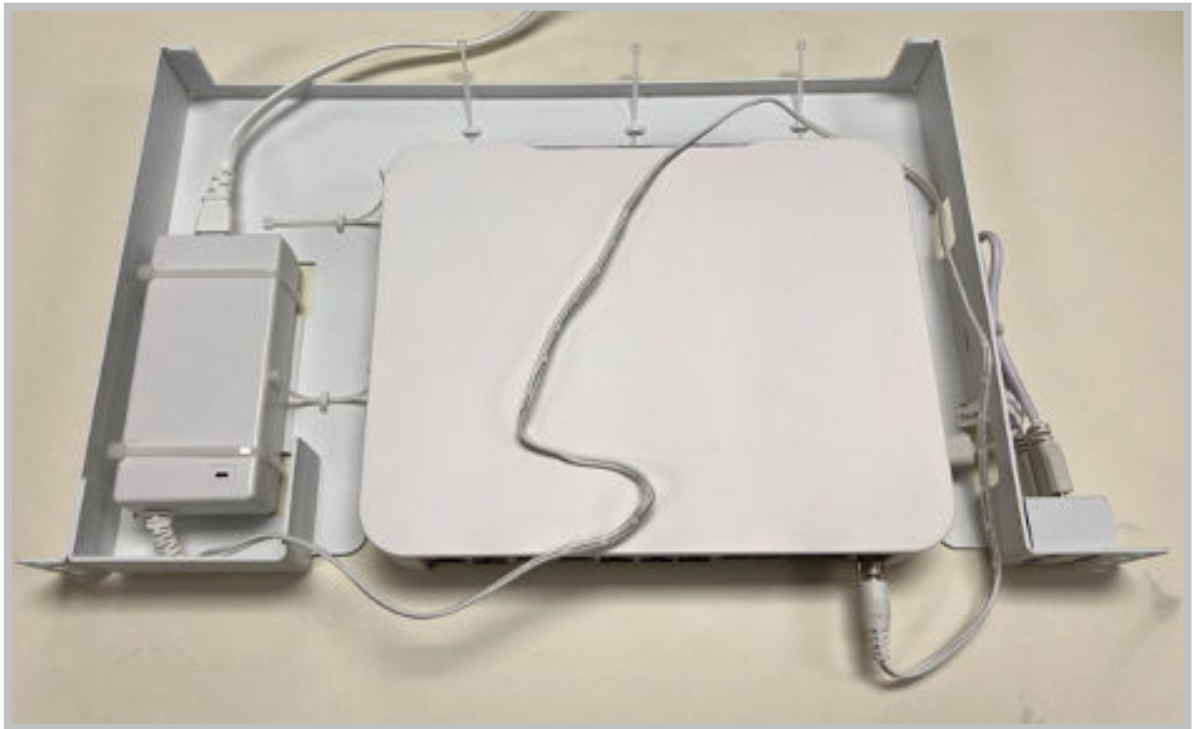

Bundle the PSU cables and route them around the rackmount bracket as shown.

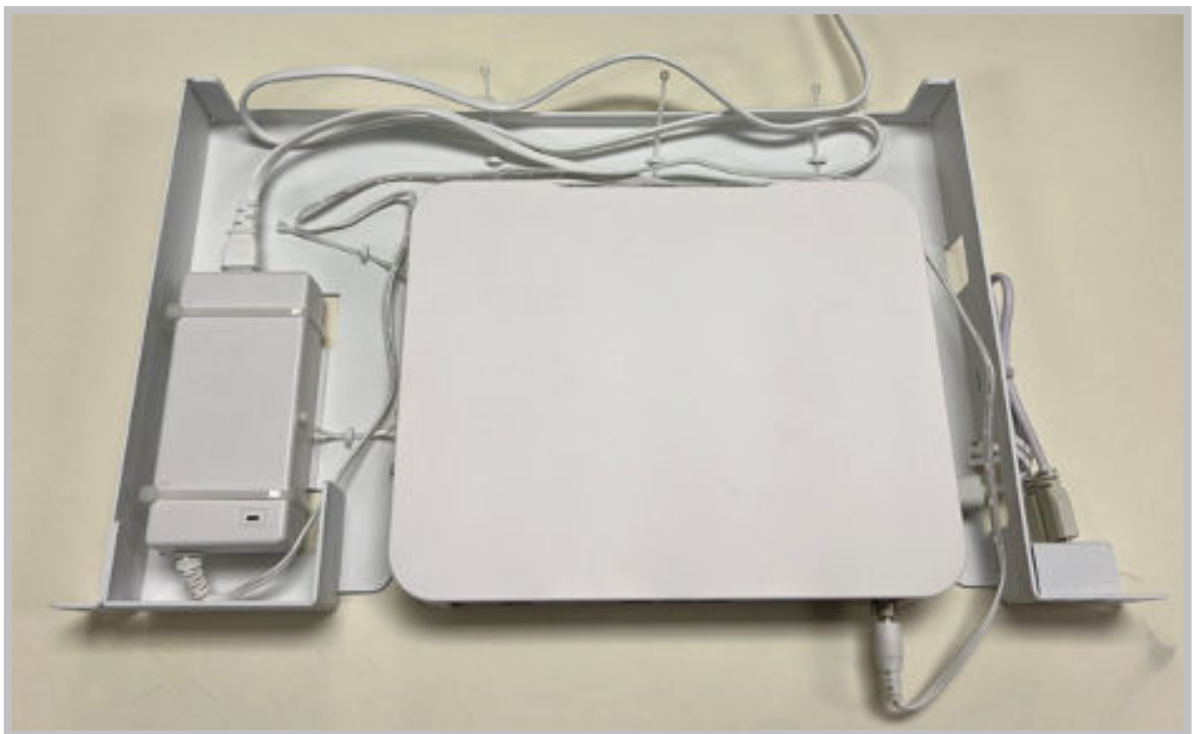

10. Secure the PSU cables with the cable ties. If necessary, bundle any excess cable slack and secure with the remaining 99mm cable tie. Snip off the excess.



Mounting the X1600 Sockets - Wallmount

The mounting brackets can be mounted in two different positions. They can protrude out from the unit in the “Outboard” position or for a cleaner look they can be mounted in the “Inboard” position behind the unit as shown below.

- **Outboard Position** - Brackets can be installed before mounting unit to the wall



- **Inboard Position** - The brackets must be mounted to the wall before mounting the unit to the wall

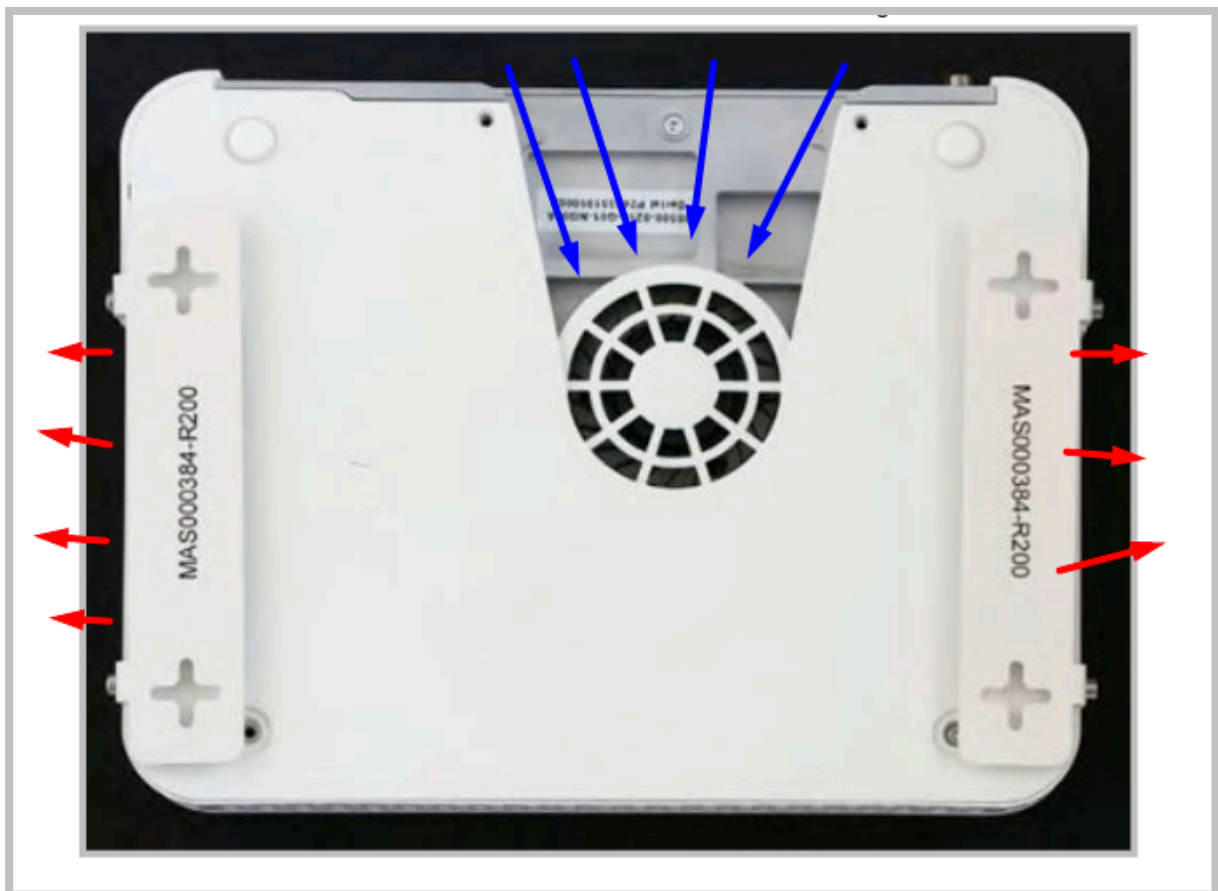



Note: The airflow for the X1600 is inbound through the rear panel (where the ports are located) and outbound through the sides of the socket. Make sure that these areas are not blocked or obstructed to enable proper cooling and venting of the Socket.

To mount the X1600 Socket on a wallmount:

1. Mount the power supply to the Power Supply mounting bracket using two cable ties as shown below.

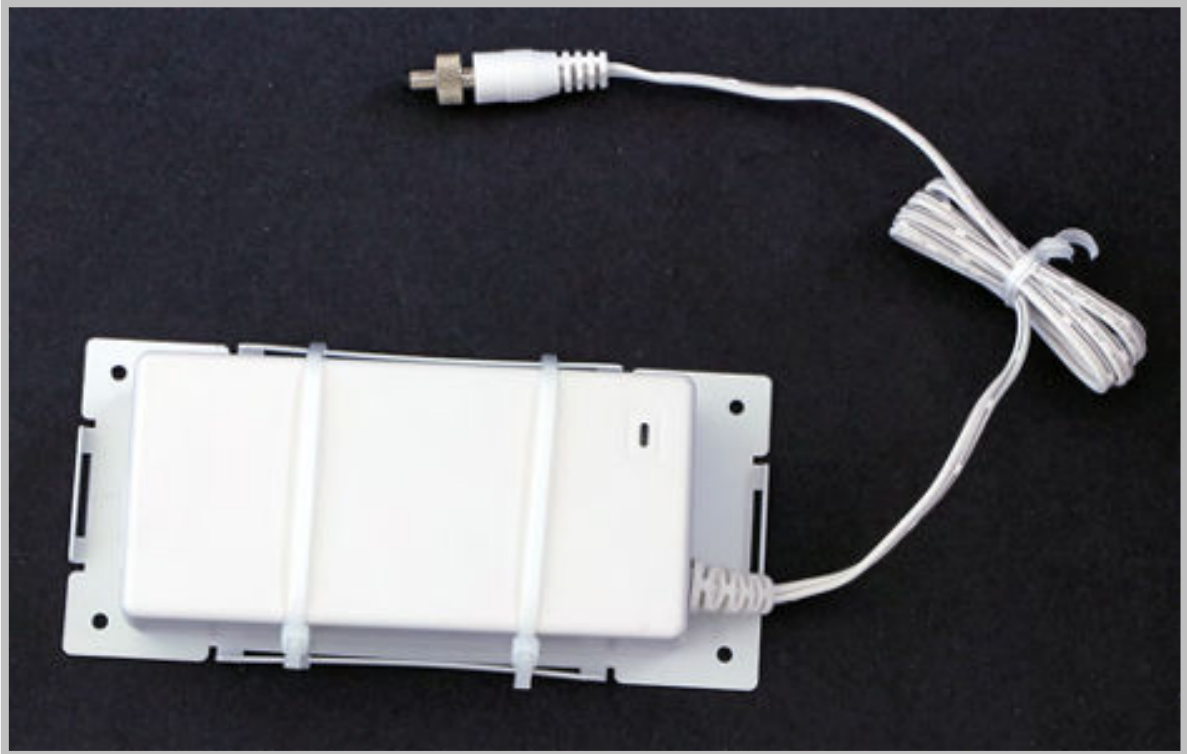

2. For the outboard position, follow these steps:
 - a. Attach the brackets to the unit using the M4 x 30mm screws.



- b. Mark the four holes on the wall for the installation.
For more information about distance between the mounting holes, see [X1600 Wallmount Reference Diagrams \[29\]](#).
- c. If needed, install the four plastic self-drilling dry wall anchors into the wall at the marked locations.
- d. Mount the unit to the wall using four M3.5x38mm screws.



Continue with step 2 below.

3. For the inbound position, follow these steps:
 - a. Mark the four holes on the wall for the installation.
For more information about distance between the mounting holes, see [X1600 Wallmount Reference Diagrams \[29\]](#).
 - b. If needed, install the four plastic self-drilling dry wall anchors into the wall at the marked locations.
 - c. Install the mounting brackets to the wall using four M3.5x38mm screws.

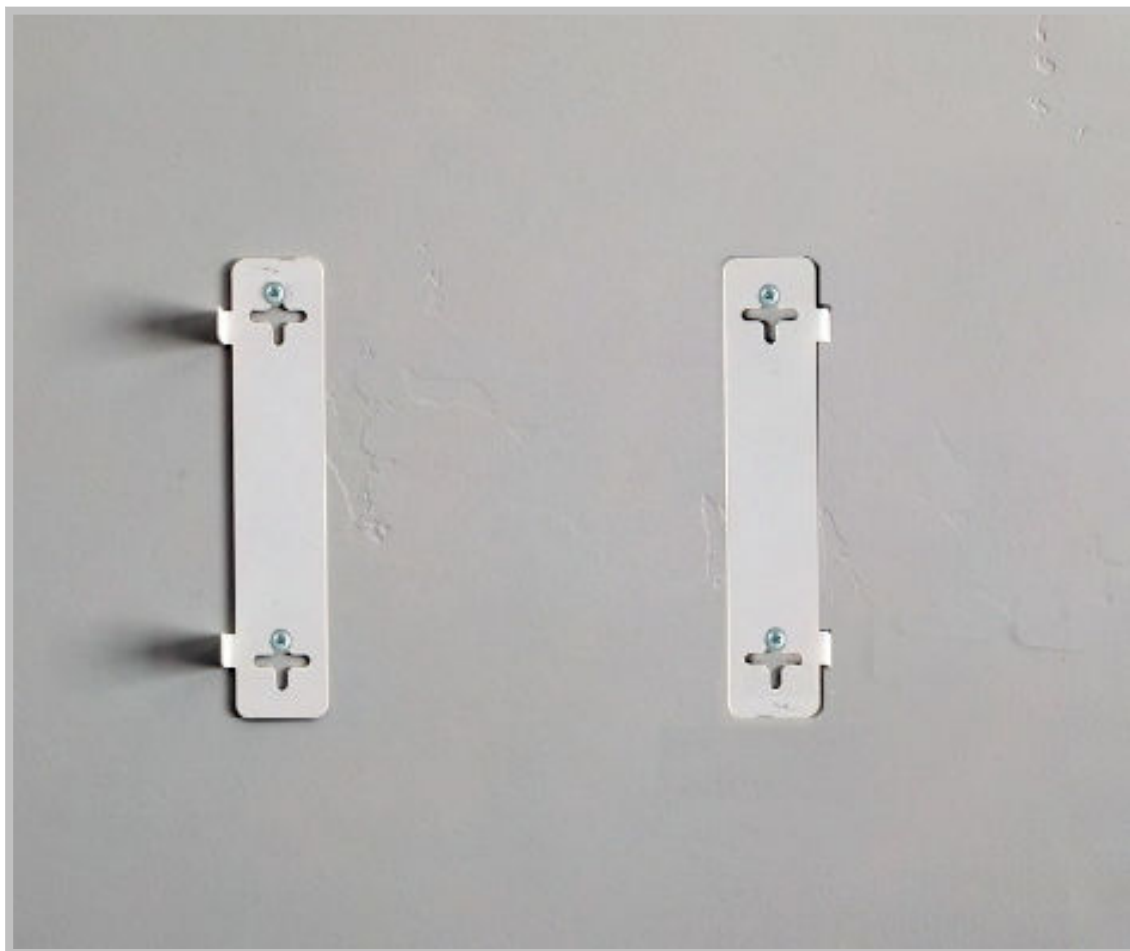

- d. Install the X1600 Socket to the mounting brackets using the M4 x 30mm screws.



Continue with step 2 below.

4. Mount the power supply to the wall next to the X1600 Socket using four M3.5x38mm screws and plug the power cable into the unit.



5. Connect the desired cables (Ethernet, Console, USB).
6. Plug the power cord barrel connector into the 12 VDC input on the unit and tighten the lock ring.



7. Plug the power cord into a properly grounded outlet.

X1600 Wallmount Reference Diagrams

These drawings are provided for reference when marking the mounting holes.

Outboard Position

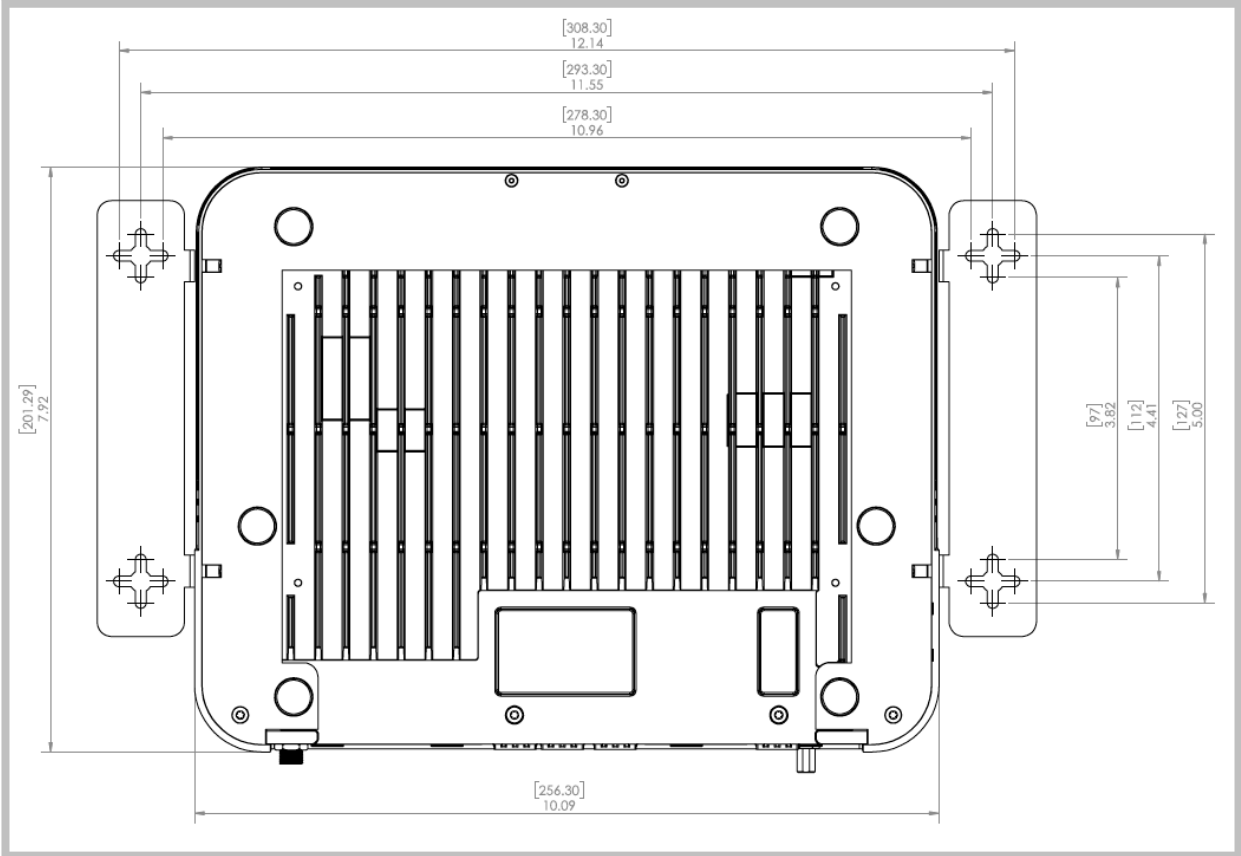

Inboard Position

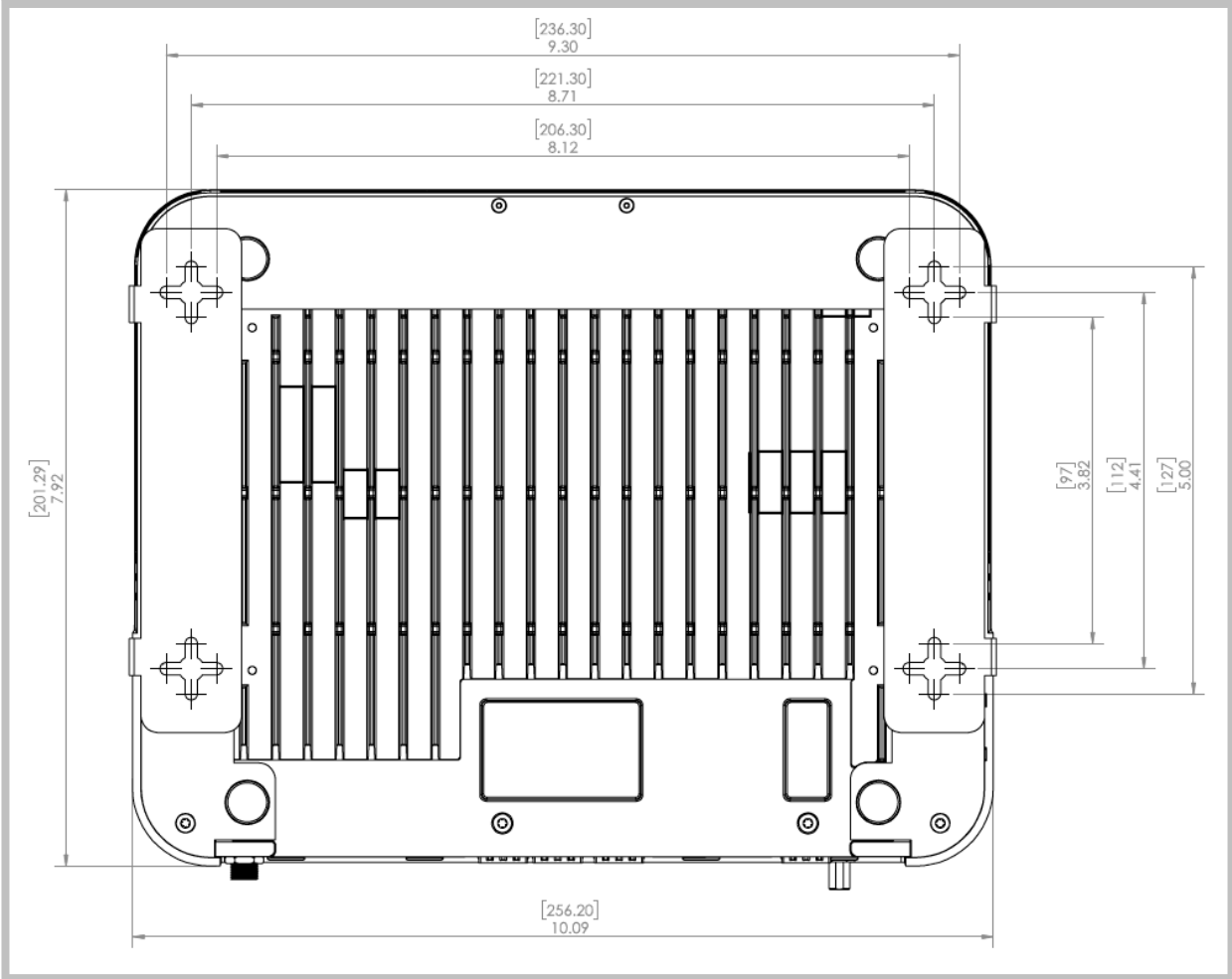

Additional Resources

- Online documentation is available in the [Cato Networks Knowledge Base](#)
- Learn more about Cato Support at: <https://www.catonetworks.com/support/>